



SAFETY: Please read carefully the mounting and the setting working instructions before put the valve into operation, in order to avoid accidents and failures caused by an incorrect use of the product. Please keep this manual for future consultations.



1" M x 1" M



1"1/4 M x 1"1/4 M



1"1/2 M x 1"1/2 M



28 mm x 28 mm



1" M x 1" nut



1"1/4 M x 1"1/4 nut

Application

Anti-freeze valve for heating/cooling systems with heat pump. The anti-freeze valve allows to protect the pipes and the heat pump from failures caused by freezing of the water inside them.

In case of shutdown of the system during the winter season, if the water temperature drops and reaches +3°C, the valve starts to open allowing a discharge, initially modest: the outflow draws the water from the side of the circuit inside the building, having a higher temperature, thus preventing the formation of ice.

If the discharge continues due to cold temperatures, in the absence of a filling group, the internal pressure of the circuit runs out and tends to reach atmospheric pressure, thus making the outflow impossible: a vacuum breaker valve present in the upper part of the valve body intervenes to allow the intake of air, allowing water drainage to continue.

The presence of an automatic circuit filling unit is recommended which, by restoring the pressure in the circuit, will bring the anti-freeze valve back to normal working conditions and the system will be able to restart autonomously.

Technical specifications

- ✓ Forged body in brass alloy. Yellow brass finish;
- ✓ Fluids for use: water;
- ✓ Maximum static pressure 10 bar (PN 10);
- ✓ Maximum medium temperature: 90 °C
- ✓ Ambient temperature range: -30°C to +50 °C
- ✓ Opening start medium temperature: +3°C
- ✓ Closing start medium temperature: +4°C
- ✓ Accuracy: ±1°C
- ✓ Inspectable vacuum breaker valve;
- ✓ Inspectable cartridge for cleaning and replacing the sensor;
- ✓ Fluid discharge rate:

P [bar]	External and fluid temperature [°C]	Q [L/min]
1	0,5	6
0,2	0,5	2,7
0,05	0,5	1,3

Materials

- ✓ Components: Copper alloy CW617N
- ✓ Gaskets: EPDM
- ✓ Springs: Steel 1.4310 (X10CrNi18-8)

ANTI-FREEZE VALVE

Dimensions and pressure drops

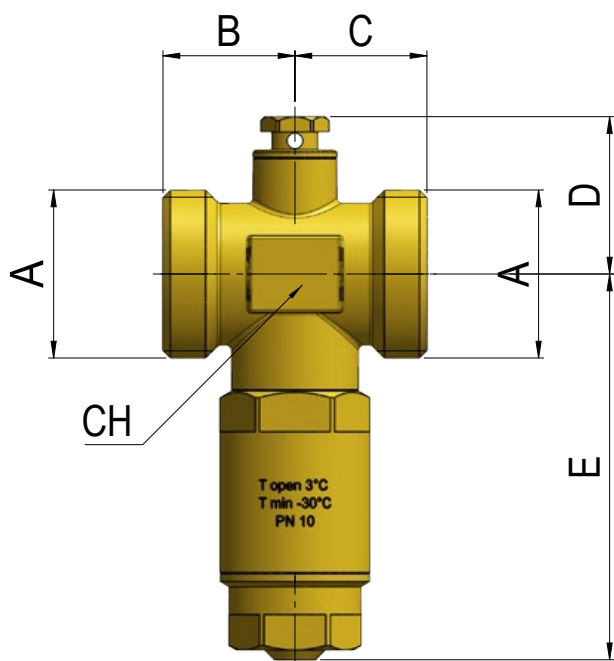

A	Kvs	B	C	D	E	CH
G 1"	68	26	26	31	76	28
G 1 1/4	90	29,5	29,5	33	78	33
G 1 1/2	103	31	31	35	80	38
28 mm	76	35,5 (*)	35,5 (*)	33	78	33

(*) Including nut and olive

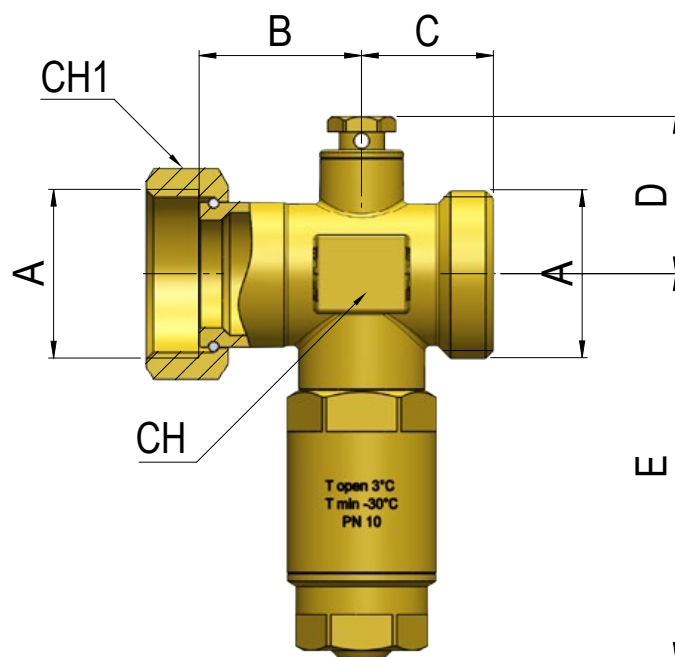

A	Kvs	B	C	D	E	CH	CH1
G 1"	68	32	26	31	76	28	37
G 1 1/4	76	41,5	29,5	33	78	33	46

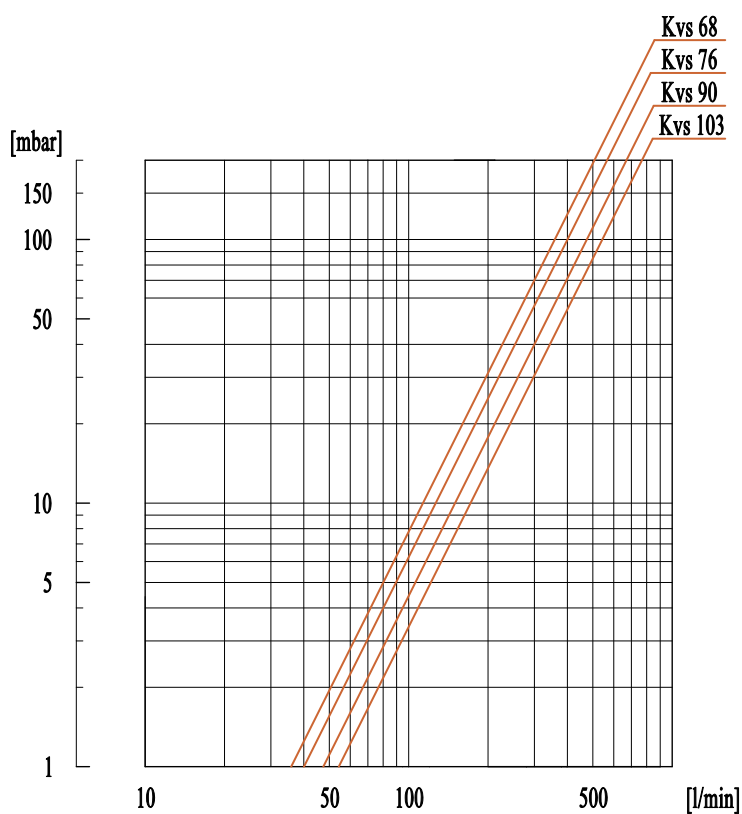

ANTI-FREEZE VALVE

Installation

For installation, rely only on qualified staff.

Check that the fluid and pipes are clean.

Installation only in vertical position, with the cartridge facing down.

The optimal installation position is outside the building, at the lowest possible point of the piping system, close to the heat pump.

It is advisable to:

- Prepare a small channel to drain the discharged liquid.
- Prepare a cover to protect the valve from snow and direct sunlight in the summer months; avoid the insulation, which would alter its functionality.
- Provide shut-off valves.

Maintain a minimum distance of 15 cm from the ground at the lowest point of the valve, to prevent the ice buildup from reaching the dripping point.

It is recommended to install two antifreeze valves, one on the flow and one on the return pipe; otherwise the pipe that does not have it may not empty and be damaged by possible freezing. Maintain a distance of at least 20 cm between the two valves.

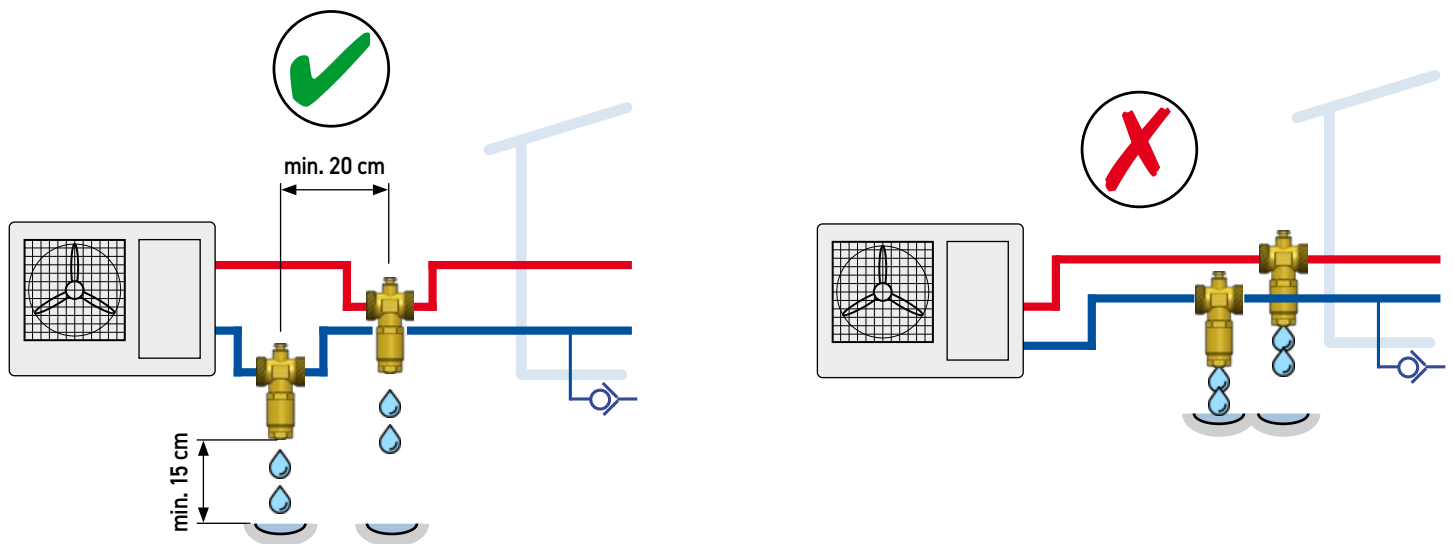

ANTI-FREEZE VALVE

Application in heating mode (winter)

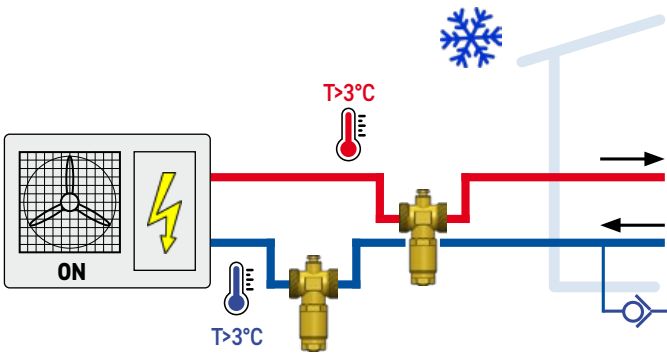

Normal operation

Pressurized system.
There is no risk of freezing of the pipes.

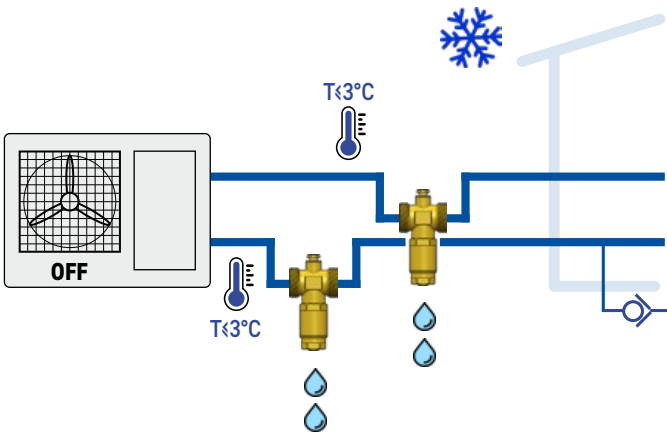

System stopped due to lack of voltage

Pressurized system (with automatic filling group).
Fluid temperature drops; when it reaches 3°C the valve starts to discharge water and the discharge continues until the temperature of the fluid in the pipe rises again to 4°C .

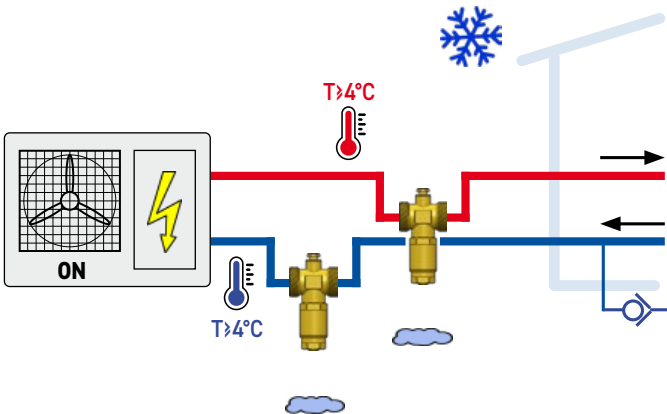

Return to operation

When the electric power returns, the heat pump resumes operation; the discharged water was compensated by the automatic filling group.
When the temperature of the fluid in the pipes rises and reaches 4°C , the anti-freeze valve closes the purge and the circuit returns to normal operation.

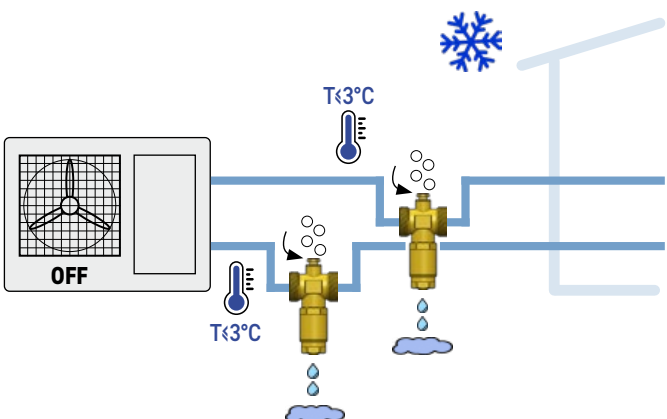

Prolonged stand still in the absence of an automatic filling unit

If the temperature remains below 3°C , after a prolonged bleeding the system is no longer pressurized.
The anti-freeze valve allows bleeding to continue until the system is emptied, thanks to the vacuum breaker valve in the upper part which allows air to enter the circuit.
In this condition, when voltage is restored, the system will have to be filled manually.

ANTI-FREEZE VALVE

Application in cooling mode (summer)

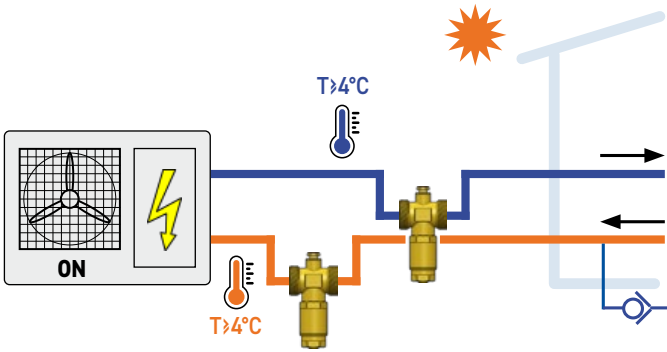

Normal operation

Pressurized system.

In this mode the fluid temperature must be higher than 4°C, at this temperature the anti-freeze valve does not intervene.

Maintenance

Close the shut-off valves upstream and downstream of the valve, to avoid emptying the system..

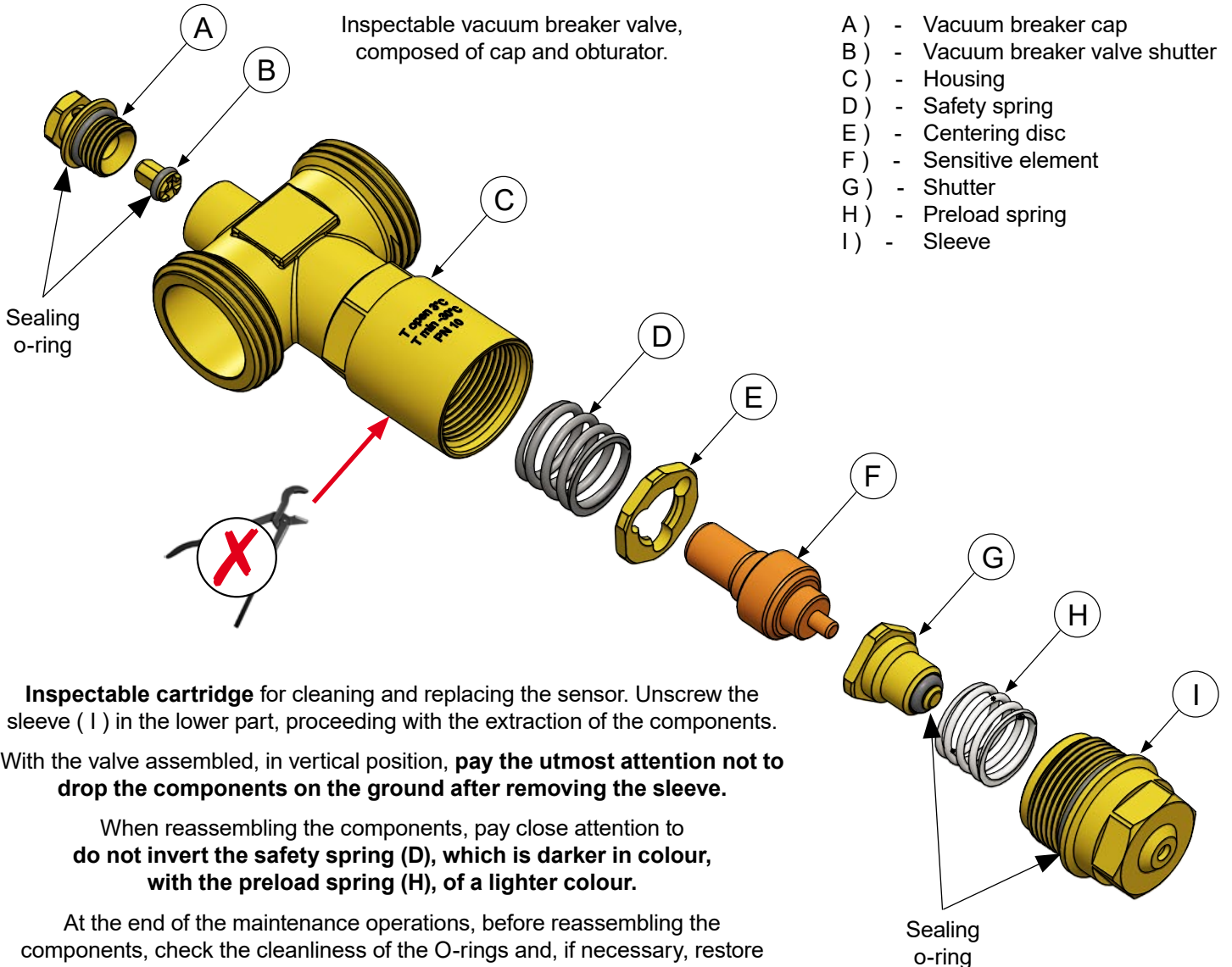

Inspectable cartridge for cleaning and replacing the sensor. Unscrew the sleeve (I) in the lower part, proceeding with the extraction of the components.

With the valve assembled, in vertical position, **pay the utmost attention not to drop the components on the ground after removing the sleeve.**

When reassembling the components, pay close attention to **do not invert the safety spring (D), which is darker in colour, with the preload spring (H), of a lighter colour.**

At the end of the maintenance operations, before reassembling the components, check the cleanliness of the O-rings and, if necessary, restore their lubrication with silicone grease. After inserting the components in the order shown in the figure, screw the sleeve (I) applying a tightening torque of 40 Nm.

